

Electronic Compensating Humidistat (Automatic Humidifier Control)

SAFETY AND INSTALLATION INSTRUCTIONS

INSTALLER: READ COMPLETE INSTRUCTIONS BEFORE BEGINNING INSTALLATION. (Throughout this document, the terms “compensating humidistat” and “humidistat” are used interchangeably.)

WARNING: This product is for residential applications only, and must be installed by a qualified HVAC contractor. Failure to comply could invalidate the product warranty, or result in serious injury or electrocution.

DANGER:

- **Disconnect electrical power to the furnace before beginning installation.** Contact with a live electrical wire can cause serious injury or electrocution.
- **Use caution when cutting plenum openings and handling ductwork.** Sharp edges can cause serious cuts and bleeding.

CAUTION:

- **Do not mount the compensating humidistat on the supply duct or plenum.** The unit will not withstand supply temperatures.
- **Do not mount the compensating humidistat downstream of the bypass outlet.** Inaccurate humidity readings will cause the humidifier to operate incorrectly.
- When installing the humidistat on down-flow furnaces, **make sure the blower continues to run after a heat call is satisfied, to prevent high temperatures from damaging the unit.**
- **Do not set the humidity so high that condensation forms on windows or walls.** Indoor condensation may result in damage to the home.

STEP 1: Check Contents of the Humidistat

Carton

Make sure the following components are enclosed (see Figure 1, above, right):

- Compensating Humidistat
- Outdoor Temperature Sensor
- Sensor Shield
- Manual Mode Faceplate
- Mounting Template

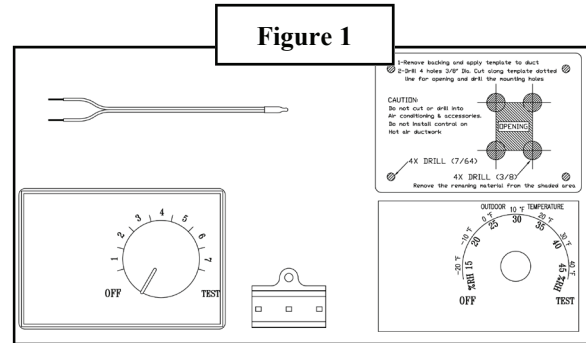

STEP 2: Disassemble the Humidistat

Pull the knob off, then remove the cover by inserting a screwdriver in the slot on the right side of the humidistat.

STEP 3: Select an Interior Location and Mount the Humidistat

Select a location to mount the compensating humidistat that is at least 6 inches upstream from any of the following (see Figure 2):

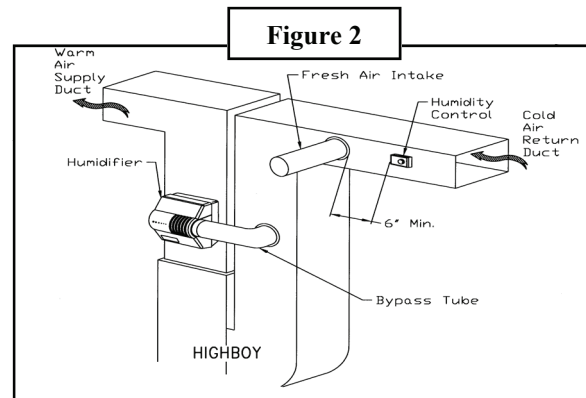

- Humidifier
- Humidifier Bypass Ductwork (if applicable)
- Fresh Air Intake Ductwork (if applicable)

Once a location has been selected, carefully position the compensating humidistat template, then drill and cut the opening. Use four sheet metal screws and the gasket (provided) to mount the unit over the duct opening. Make sure the humidistat is sealed tightly to the duct.

continued...

STEP 4: Select an Exterior Location to Mount the Outdoor Temperature Sensor

Placement of the outdoor temperature sensor must meet these requirements:

- It must be mounted on the North, Northeast or Northwest side of the house, where direct sunlight will not influence the sensor.
- It must be placed at least 3 feet from all exhaust vents.
- It must be installed above the expected snow line (see Figure 3).

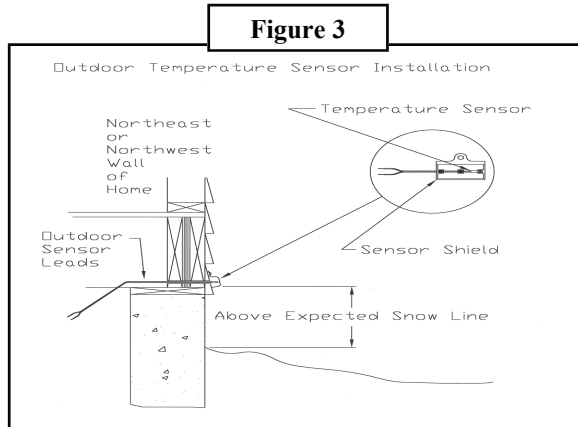

CAUTION: Incorrect indoor humidity levels will result if these requirements are not met.

NOTE: For manual operation, do not install the sensor wire.

STEP 5: Locate an Existing Indoor/Outdoor Access Hole

If possible, insert the sensor cable through an existing indoor/outdoor access hole for cable TV lines, telephone lines, A/C lines, etc.

CAUTION: Make sure there are no active high-voltage wires in the hole.

As an alternative, the sensor can be mounted in the center of a 6-inch fresh air intake duct.

However, the sensor bulb must be no further than 30 inches from the outside wall. (See Figure 4.)

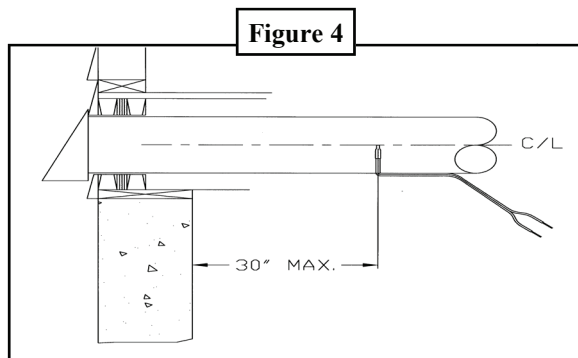

The sensor can also be mounted in the center of a 6 inch pipe used for make-up air or combustion make-up air devices. The sensor must be no further than 30 inches from the outside wall.

NOTE: If it is not possible to install the outdoor temperature sensor in any of these configurations, the compensating humidistat can be installed to operate manually. (See “Installing the Compensating Humidistat to Operate Manually”, page 4.)

STEP 6: Route the Sensor Wire to the Selected Location

Run wire between the compensating humidistat and the outdoor sensor lead. If the sensor is outdoors, snap the probe end of the sensor into the sensor shield and attach it to an exterior wall. The probe must be completely covered by the shield.

NOTE: The outdoor temperature sensor wire must not exceed 30 feet in length.

CAUTION: Do not run outdoor temperature sensor wire alongside wires carrying high voltage (120 VAC or higher). Do not run the sensor wire through conduit.

STEP 7: Attach the Sensor Wire to the Humidistat

Strip the connecting wire 1/4" and attach the two internal wires to the terminals labeled “Outdoor Temperature Sensor” on the humidistat.

STEP 8: Select a Power Source

Select a source for 24 VAC to power the compensating humidistat, based on the following options:

For furnaces with accessory terminals...

- If the accessory terminals provide 24 VAC, wire them to the “24 VAC” terminals on the humidistat.
- If the accessory terminals provide 120 VAC, wire them to a 24 VAC transformer; connect the transformer to the “24 VAC” terminals on the humidistat.

For other furnaces, a 24 VAC transformer must be added.

- Wire into a power source other than the furnace accessory terminals. (The transformer can be powered off the 120 VAC line at the junction box, before it enters the furnace.)
- Connect the 24-volt side of the transformer to the “24 VAC” terminals on the compensating humidistat.

In either configuration, the voltage to the humidistat must be between 22 and 30 VAC.

continued...

NOTE: The compensating humidistat will operate properly with either a switched or continuous power source. Whether you are using accessory terminals or an external transformer, a minimum 10 VA (volt amperes) is required.

STEP 9: Connect the Compensating Humidistat to the Humidifier

Strip the wires used for all the humidistat terminal connections 1/4 inch.

If furnace accessory terminals are used... wire the solenoid valve directly to the “Out” terminals on the humidistat. Also attach a jumper wire to the wire connector, as shown in figures 5 and 6. **Do not use a current-sensing relay.**

If an external transformer is used... Connect a current-sensing relay in series with the solenoid valve and the “Out” terminals on the humidistat. This will allow the humidifier to operate only when the furnace blower is on. (See Figures 5-7 to determine the correct wiring for your model humidifier.)

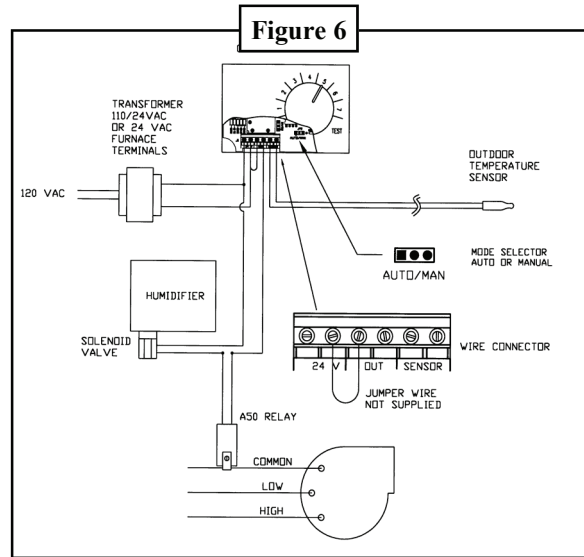

Applies to Bypass Flow-Thru and Under Duct Humidifiers

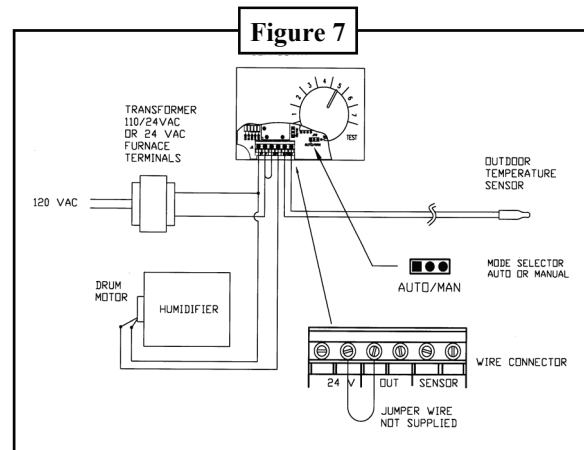

Applies to Drum (Reservoir) Humidifiers

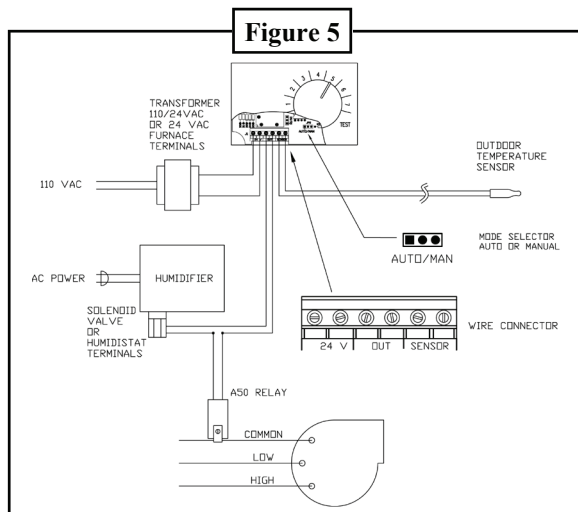

Applies to Fan-Powered Flow-Thru Humidifiers

NOTE: For installation of the Electronic Compensating Humidistat with Steam Units, see the **Wiring Instructions for High-Capacity Steam Humidifiers**.

If you do not have the **Wiring Instructions**, they are available online at www.skuttle.com or by calling (toll-free) 888-SKUTTLE (758-8853).

continued...

INSTALLING THE COMPENSATING HUMIDISTAT TO OPERATE MANUALLY

If it is not possible to use the outdoor temperature sensor, or if the homeowner wants to control the humidifier manually, the humidistat can be reconfigured for manual operation. (see Figure 8.)

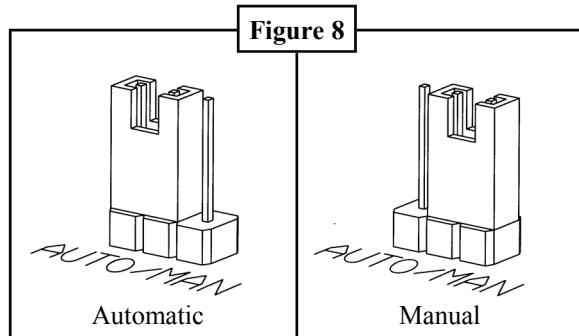

1. Locate the three-pin arrangement marked AUTO/MAN, protruding from the control board (directly to the right of the wiring connections).
2. Pull upward to remove the black, two-pin connector from the auto position. Reinstall it in the manual position (on the center and right-hand pins).

CAUTION: Do not attach sensor wire to the blue wiring connection block.

3. Follow Steps 8 and 9 to complete the wiring.
Apply the manual-mode faceplate to the compensating humidistat cover. Reattach the cover to the base and reinstall the knob.

SYSTEM CHECKOUT

1. To conduct a system test, be sure that 24 VAC is applied to the 24 VAC terminals of the compensating humidistat.
2. Reattach the humidistat cover and knob to the base.
3. Activate the furnace blower and confirm that the thermostat is calling for heat.
4. Rotate the knob on the humidistat clockwise (↻) to the “Test” position.
 - If everything is set up correctly, the humidifier should begin operating. In “Test” mode, the humidistat will operate for approximately one minute.
 - If the humidifier does not activate properly in “Test” mode, refer to the Troubleshooting Guide, below.
5. Set the compensating humidistat.
 - If the home is occupied, set the humidistat knob to “5”. (For manual operation, set the knob to “35%”.)
 - If the home is vacant, turn the humidistat knob counterclockwise (↺) to “Off”.
6. Tell the homeowner to refer to the Compensating Humidistat Operating Instructions for direction regarding initial adjustment.

TROUBLESHOOTING GUIDE

(applies to automatic and manual operation, unless otherwise indicated)

PROBLEM

Humidifier does not operate in “Test” mode

SOLUTION(S)

- Make sure the furnace blower is operating and the thermostat is calling for heat.
- Confirm that the outdoor temperature sensor is connected to the “Outdoor Temperature Sensor” terminals on the compensating humidistat. (For manual operation, make sure the jumper pins are positioned correctly.)
- Check the wiring diagrams (Figures 5-7) for correct installation.
- Check the voltage at the humidistat “24 VAC” terminals. (Voltage should be between 22 and 30 VAC.)
- Check the current-sensing relay (if used) for proper installation. **(The relay is to be wired to the “Out” circuit only.)**
- Make sure the control knob has not been left in the “Test” position. In “Test” mode, the humidifier will not continue to operate after approximately one minute.

continued...

TROUBLESHOOTING GUIDE (cont'd.)

PROBLEM

Humidifier operates only in “Test” mode

SOLUTION(S)

- Check the resistance of the sensor by removing the leads from the humidistat terminals, and measuring the resistance across the wires with an ohmmeter. Compare the reading to the temperature/resistance chart, below.

Temperature/Resistance Chart		
100°F	6,000 ohms	38°C
90°F	7,500 ohms	32°C
80°F	9,500 ohms	27°C
70°F	11,500 ohms	21°C
60°F	14,000 ohms	16°C
50°F	18,000 ohms	10°C
40°F	23,000 ohms	4°C
30°F	28,500 ohms	-1°C
20°F	37,000 ohms	-7°C
10°F	46,500 ohms	-12°C
0°F	61,500 ohms	-18°C
-10°F	78,500 ohms	-23°C
-20°F	105,500 ohms	-29°C
-30°F	135,000 ohms	-34°C

For automatic applications...

- Make sure the outdoor temperature sensor is mounted completely outside the house (i.e., not recessed into the hole) on the North, Northeast or Northwest side, away from direct sunlight.
- Make sure the outdoor temperature sensor is mounted at least three feet away from all exhaust vents.
- If the outdoor temperature sensor is mounted in the fresh air intake duct, make sure the probe is no further than 30 inches from an outside wall.

NOTES:

In AUTOMATIC applications, if the outdoor temperature is greater than +50°F (+10°C) or less than -32°F (-35.6°C), the compensating humidistat will not operate (except in “Test” mode).

In both AUTOMATIC and MANUAL applications, if the relative humidity in the home is higher than the knob setting, the compensating humidistat will not operate the humidifier. Similarly, the humidistat will not operate if the indoor relative humidity exceeds 45 percent.

Humidifier operates constantly

- Check the humidistat setting. If the relative humidity in the home is less than the knob setting, the humidifier will operate until the humidity level is higher than the knob setting.
- In the “Test” mode, verify that the humidifier will shut off after approximately one minute.
- Check the resistance of the sensor. (See previous section.)

continued...

**Humidifier operates constantly
(cont'd.)**

**Humidifier or compensating
humidistat “chatters” or clicks
on and off rapidly**

For automatic applications...

- Make sure the outdoor temperature sensor is mounted completely outside the house (i.e., not recessed into the hole) on the North, Northeast or Northwest side, away from direct sunlight.
- Turn the compensating humidistat knob counterclockwise (↺) to the “Off” position and observe whether the humidifier turns off. If the humidifier continues to operate, perform the following:
 - Check the wiring diagrams (Figures 5-7) for correct installation.
 - Remove the wires from the humidistat’s “Out” terminals. If the humidifier continues to operate, check the humidifier.
- Use a voltmeter to check for a steady 22-to-30 VAC.
- For automatic applications, make sure the outdoor temperature sensor wiring does not run alongside wires carrying high voltage (120 VAC or higher).